



BFG

Manual assembly benches



Assembly bench for fitting the aluminium frame with gasket and glazing. The glazing is lifted via a spider clamp and, thanks to a system of self-aligning vices, the frames are pressed two-by-two. After pressing on the first two sides, the spider clamp is rotated and then it is possible to press on the other two sides.

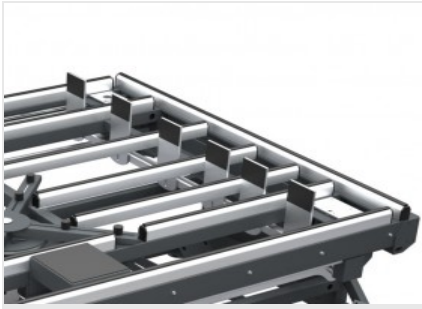

Pressing system by square footage

Two parallel carriages driven by large cylinders allow the profile to be inserted on the glass, up to a minimum sash size of 400 x 400 mm.



Adjustable feet

Height adjustable feet to ensure the work bench can be positioned at the required height and perfectly flush with the other products in the Dynamic Line. The feet also have holes so they can be anchored to the floor.



Support surface in hard anti-friction PVC

The anti-friction hard PVC support surface ensures great smoothness of the frame allowing easy handling.



BFG / MANUAL ASSEMBLY BENCHES

WORK BENCHES

Hard anti-friction PVC contact surface ●

WORKPIECE LOCKING

BFG 2400 maximum pressing dimensions (mm)	2.400 x 2.400
BFG 3000 maximum pressing dimensions (mm)	3.000 x 3.000
Minimum pressing dimensions (mm)	400 x 400

DIMENSIONS

Length (mm)	3000
BFG 2400 overall dim. L x D x H (mm)	3.420 x 1.950 x 990
BFG 3000 overall dim. L x D x H (mm)	3.600 x 1.950 x 990

CHARACTERISTICS

2-position pneumatic glass lifting system ●

Included ● Available ○